

C7150B Temperature Sensor

INSTALLATION INSTRUCTIONS

APPLICATION

The C7150B Temperature Sensor is used with the W973 Single Zone System, the M7415A Motor, or Economizer Logic Modules (W7210, W7215, W7459, W7340) to sense mixed or discharge air in rooftop packaged air conditioning equipment.

SPECIFICATIONS

Models: See Table 1.

Dimensions: See Fig. 1.

Mounting Arrangement:

Integral mounting flange that requires No. 8 screws.

NOTE: The C7150B1004 requires four No. 8 screws; the C7150B1046 requires two No. 8 screws.

Ambient Temperature Ratings:

Maximum: 250°F (121°C).

Operating Range: -40 to 110°F (-40 to 43°C).

Shipping Range: -30 to 150°F (-34 to 66°C).

Wiring Connection: 1/4 in. (6 mm) quick-connects.

NOTE: The C7150B1046 includes 4 in. lead wires with connector for W7340 compatibility.

Table 1. C7150B Models.

Model	Nominal Resistance at 77°F (25°C)	Nominal Sensitivity ^a at midrange
C7150B1004	3000 ohms	70 ohms per °F (124 ohms per °C)
C7150B1046	10K ohms	234 ohms per °F (415 ohms per °C)

^a Negative Temperature Coefficient (NTC).

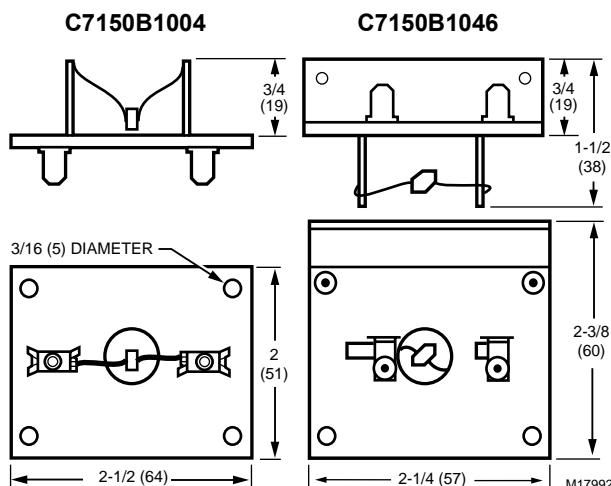

Fig. 1. C7150B approximate dimensions in in. (mm).

INSTALLATION

When Installing this Product...

1. Read these instructions carefully. Failure to follow them could damage the product or cause a hazardous condition.
2. Check the ratings given in the instructions and on the product to make sure the product is suitable for your application.
3. Installer must be a trained, experienced service technician.
4. After installation is complete, check out product operation as provided in these instructions.

IMPORTANT

All wiring must agree with applicable codes, ordinances and regulations.

1. Install on a mounting bracket (not included) inside the mixed air or discharge air duct using No. 8 mounting screws and nuts. (See Fig. 2).

NOTE: When mounting, ensure that terminals do not touch metallic conductive surfaces.

2. Wire using 1/4 in. (6 mm) female quick-connect terminated wires from C7150B to control inputs.

NOTE: For C7150B1046, splice additional wiring as needed between sensor and connector.

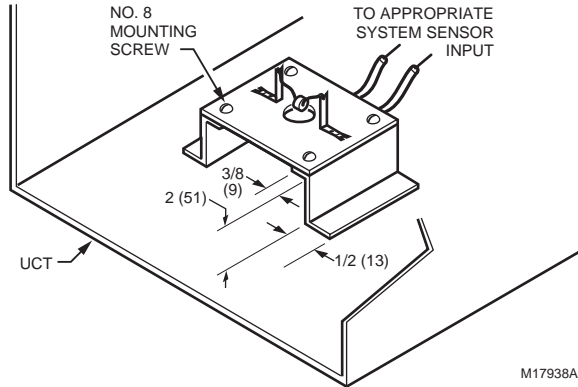

Fig. 2. Mounting C7150B [C7150B1004 shown].

NOTE: Fig. 2 displays bracket (not included) and suggested bracket dimensions in in. (mm).

OPERATION

The C7150B Air Temperature Sensor consists of a thermistor sensing element mounted on a phenolic board. It is applied in ventilation duct systems. The thermistor element negative temperature coefficient (NTC) characteristic causes its resistance to decrease as the sampled air temperature increases. This resistance change is used as a control system sensor to regulate discharge air temperature in a W973 Single Zone System or damper position of the M7415A Motor (either directly, or through the Economizer Logic Module).

CHECKOUT

Allow the C7150B sensor to soak in the air moving through the duct for a minimum of 5 minutes before taking a resistance measurement:

1. Disconnect sensor leadwires from associated system components.
2. Connect an ohmmeter across the leadwires.

3. Nominal resistance measurements should be in accordance with the resistance/temperature curves shown in Fig. 3 and 4.
4. Reconnect sensor leadwires to associated system components.
5. Check operation of the M7415A Motor, W973 System, or the Economizer Logic Module.

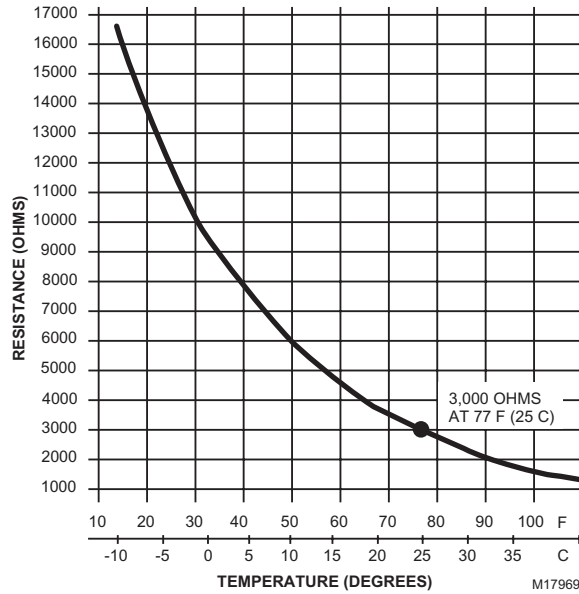

Fig. 3. C7150B1004 Sensor resistance temperature.

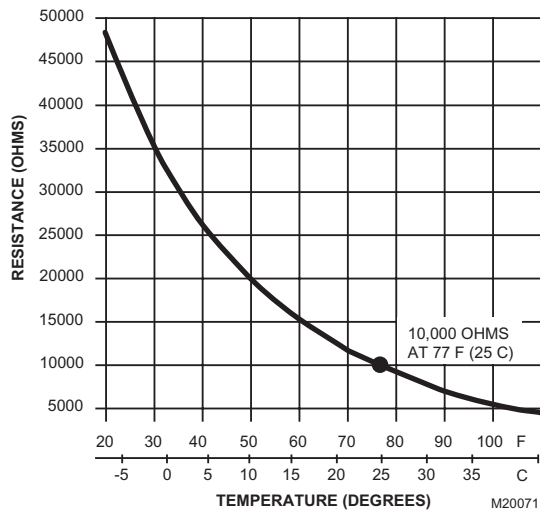

Fig. 4. C7150B1046 Sensor resistance temperature.

Honeywell

Automation and Control Solutions

Honeywell
1985 Douglas Drive North
Golden Valley, MN 55422

Honeywell Limited-Honeywell Limitée
35 Dynamic Drive
Scarborough, Ontario
M1V 4Z9

